

Installing a cold water storage cistern

Checklist

✓ Installing inlet valves

A securely and rigidly fixed inlet valve which shuts off the flow at a set level within the cistern must be fitted. Typically, this level is a minimum of 25 mm below the overflow but should be increased to a minimum of 50 mm if there is no warning pipe. Where a float operated valve is to be used, this must be capable of being adjusted to ensure that the inlet valve closes at a defined level.

✓ Installing outlet valves

Where practicable all outlets from a storage cistern should be located at the bottom of the cistern, and to encourage mixing and prevent areas of stagnation or 'short circuiting' within the cistern, on the opposite side to the inlet.

All outlets from cold water storage cisterns, except vent pipes, overflow pipes and warning pipes, should be fitted with a servicing valve as close to the cistern as is reasonably practicable.

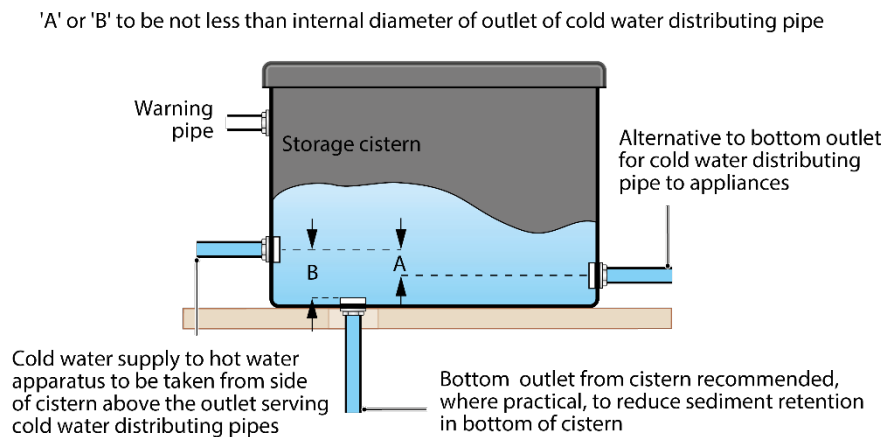

✓ Installing an overflow pipe

Every cold water storage cistern must be fitted with an overflow pipe.

To help minimise waste a suitable means of warning of an impending overflow must also be installed. A warning pipe is commonly used for this purpose, but with the local water undertaker's agreement alternatives may be fitted.

Further information can be found [here](#)



Protecting a cold water cistern installation

To minimise undue warming, which can affect the wholesomeness of water, cold water storage cisterns and related pipework should be sited away from heat sources and insulated.

To help prevent damage due to freezing cold water storage cisterns plus any pipework at risk, should be protected. The type and level of protection will be dependent on where the installation is located.



How should a cold water storage cistern be installed ?

Things to consider when deciding where and how to install include but are not limited to:

- whether the distributing pipework is to be pumped or supplied by gravity
- the need to allow for ease of access for maintenance, inspection (both internally and externally) and cleaning.
- environmental factors which might affect water quality such as excessive heat gain or the likelihood of flooding

Float operated valves and other controls should be readily accessible. There should be sufficient clearance to allow for inspection, cleaning of internal surfaces and maintenance. Cisterns with a capacity greater than 1,000 litres should be capable of being inspected and cleansed without having to be wholly uncovered.

To avoid distortion cold water storage cisterns should be adequately supported. Advice on how to do this can be found in Part G of the Building Regulations.

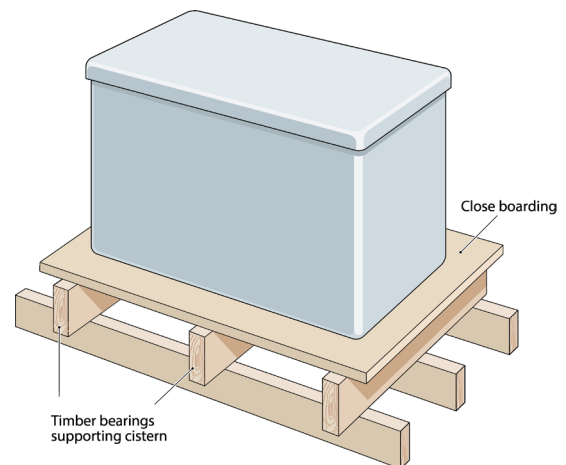
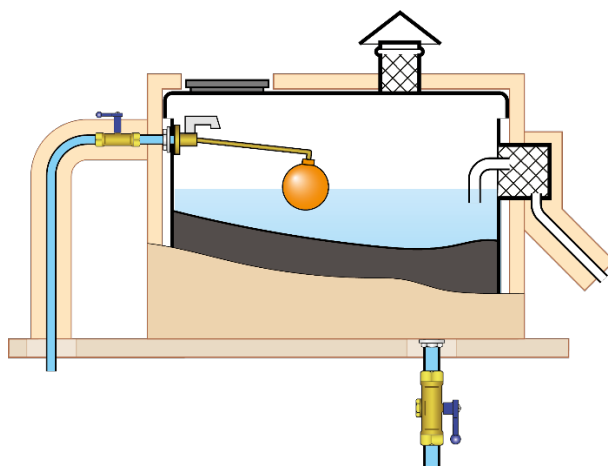

Please note other requirements apply refer to the Guidance published by Water Regs UK for further information

<https://www.waterregsuk.co.uk/guidance/>

